



de manincor

ITALIAN MASTERPIECES SINCE 1828

bespoke kitchens



de manincor

ITALIAN MASTERPIECES SINCE 1828



“For 5 generations
we’ve practiced
a form of art:
producing kitchens
in which innovative
technology and
artisanal care coexist
in harmony”

Walter de Manincor

Ceo

Where craftsmanship and industry meet

DeManincor is synonymous with tradition and innovation.

Guaranteed exclusive quality due to a unified synergy between traditional artisan technique and the innovative capacity of industrial work.

Each of our products proudly beholds the promise of Italian excellence and is made in our factory in Trento with the same care and passion founded over 180 years ago.

We are a modern, technically advanced industrial reality, always ready to face new challenges thanks to centuries-old secrets of artisan traditional.





“We fulfill even
the most particular
requests because we
don’t like to limit our
customers. A passion
that traces back to
1828”

Mattia de Manincor
Sales & Marketing Director

The preferred kitchens of Michelin- starred chefs



Massimiliano Alajmo · LE CALANDRE
Heinz Beck · LA PERGOLA
Enrico Crippa · PIAZZA DUOMO
Annie Féolde · ENOTECA PINCHIORRI



Francesco Bracali · BRACALI
Antonio Mellino · QUATTROPASSI
Giancarlo Perbellini · CASA PERBELLINI
Valeria Piccini · DA CAINO
Gaetano Trovato · ARNOLFO
Gerhard Wieser · TRENKERSTUBE



Riccardo Aiachini · LA FERMATA
Francesco Apreda · IMAGO
Paolo Barrale · MARENNA
Andrea Berton · BERTON
Salvatore Bianco · IL COMANDANTE
Alfonso Caputo · TAVERNA DEL CAPITANO
Valentino Cassanelli · LUX LUCIS
Lorenzo Cogo · EL COQ
Roberto Conti · TRUSSARDI ALLA SCALA
Umberto De Martino · FLORIAN MAISON
Giuseppe Di Iorio · AROMA
Paolo Donei · MALGA PANNA
Sabino Fortunato · IL GALLO CEDRONE



Maurilio Garola · CIAU DEL TORNAVENTO
Maurizio Grange · LA CLUSAZ
Antonio Guida · IL PELLICANO
Agostino Iacobucci · I PORTICI
Giuseppe Iannotti · KRESIOS
Francesco Brutto · VENISSA
Nobu Matsuhisa · ARMANI NOBU
Massimiliano Musso · CA' VITTORIA
Davide Palluda · ALL'ENOTECA
Elia Rizzo · IL DESCO
Diego Sales · CASTEL FRAGSBURG
Luigi Tramontano · TERRAZZA BOSQUET





Aesthetics and functionality without compromise

We internally design and produce all of our kitchens, using strictly artisanal techniques in which every single component is carefully studied, creating products that are at once exclusive and in line with the style and needs of the user.

From cooking ranges to ventilation systems to solutions for freezing and conservation, each of our kitchens possess a harmonious balance of form and functionality consenting us not only to satisfy the most detailed requests but to make our way into the hearts of our customers.

With DeManincor, beauty and efficiency are part of the home.

We give our clients and designers the freedom to imagine a world without limits

The meeting point between experience in great kitchens and the artisanal background of our company gives way to Bespoke Kitchens, a studied line for the gourmet connoisseur.

Imagine being able to choose dimensions, furnishings, color and equipment for a one-of-a-kind kitchen, unique and unrepeatable.

A kitchen that is elegant on the outside and technical on the inside.

A kitchen perfectly realized down to the minutest detail, stemming from innovative and revolutionary design. A kitchen that allows you to cook at home with the same professional technique and composition of the greatest restaurants.

Cooking ranges, islands, peninsulas or entire kitchens. The solutions are endless, capable of turning your wildest dreams into reality.

From the first site inspection to the finished product, our special commissions result in an exclusive experience for you, and for your idea of perfection.



...

Unmistakable design,
Glossy Brass trim
paired with warm
tones of Chocolate
Brown and spacious
dimensions. A
refined way of
integrating luxury
and functionality in
the heart of Moscow.













Frytops in cast iron or Teppanyaki



Positioned inside a watertight basin that allows for easy cleaning at the end of use, the Gas frytop for direct cooking is heated by a special burner extended by 4.4kW of power in order to distribute the temperature over the entire surface and ensure homogeneous cooking.

There are 2 models of Gas frytop: the Japanese Teppanyaki, perfectly smooth in polished stainless steel and the reversible (double faced) smooth/ribbed finish in black enameled cast iron.

The smooth/ribbed Frytop is also available as an electric frytop.

In London, pastel
nuances, wide
open spaces and
plentiful light for a
kitchen that blends
aesthetic quality
with functionality.
For those who seek
to brighten gray city
days.









Traditionally innovative



DeManincor kitchens can also include traditional wood burning ranges.

These machines, certified and tested according to the most rigorous European norms, are realized with modern fireboxes in cement refractory bricks that allow the kitchen to accumulate heat and gradually disperse warmth throughout the room.

The enameled oven of the wood burning kitchen and the cast iron plate are ideal for traditional culinary preparations, increasingly appreciated and researched.

Large drawers allow for order in the kitchen.

The stainless steel plate of the wood kitchen is considered without a doubt the antithesis to the modern Coup-de-Feu solid tops.

A combination of the highest performing elements of the professional modern kitchen, from the powerful Gas burners to the electric and induction burners.

An Italian in Paris.
Satin Copper and
Glossy Copper
alternate in a play
on textures and
finishes for a result
that is très chic.









Professional burners



Our Gas burners have a power potential of up to 6kW and, excluding the small burner (2kW), are all composed of double rings. The composition of burners and their powers can be customized for each element of cooking.

The burners are watertight and immersed in a large, indented collection tank equipped with a drain for quick and easy cleaning at the end of service.

The Coup-de-Feu solid top has a vertical flame to enhance the functions of the cast iron surface. Thanks to a simple adapter, it lends itself perfectly to Wok cooking.

Like a dive into the
turquoise waters of
Saint-Tropez, this
kitchen perfectly
interprets the
nautical style of the
Côte d'Azur.









Fine dining appliances



The smooth Teppanyaki electric plate is made of stainless steel with a perimeter channel for running water.

This feature is dually functional: on one hand, it simplifies cleaning at the end of service while also acting as a formidable thermal break between the frytop and the work surface.

The plate guarantees an extremely precise temperature thanks to digital regulation and two special probes.

A breathtaking
view of Milan for
an open kitchen
with a sophisticated
design in chromatic
and materialistic
harmony with the
environment.









Steamer or Pasta Cooker?



A tried and true professional 13lt Pasta Cooker with two robust detachable straining baskets capable of managing large quantities of pasta of any shape and size. The baskets contain a fine grid for straining even the most delicate of pastas.

The same Pasta Cooker, thanks to the technology of DeManincor, can be used as a Steamer by varying the water levels and using the overlapping GN 2/3 baskets (h6cm and h15cm) which allow for simultaneous cooking. During cooking, the device is coverable by a glass lid.

When not in use, a stainless steel cover fits perfectly in line with the cooking surface hiding the Pasta Cooker and creating a workspace while protecting the equipment.

An innovative and
creative project
for lovers of
unconventional design.
In South Beach, Black
Velvet tones with trim
in Glossy Black for a
contrast suitable to
true connoisseurs.









Low and slow



The solid top is made of heavy cast iron with a central circular burner and a powerful 4.4kW burner.

Excellent for preparations at low, constant temperatures (plaque de mijotage), ideal for better managing stand-by situations, and moreover useful for when you need to accelerate cooking by taking advantage of the “firing point” of the central vertical flame burner, the so-called Coup-de-Feu.

As in a large professional kitchen, the solid top is inserted together with Gas burners, inside a shallow basin designed to easily manage cleaning at the end of use thanks to a convenient drain.

In order to take full advantage of the entire surface area and avoid boil overs, the plate is at the same height as the side burner grills.

Cooking ranges at the heart of the kitchen

Cooking ranges are at the center of the DeManincor kitchen; the beating heart of each one of our projects.

Innovative, state-of-the-art, and functional in design, the Bespoke Kitchen cooking ranges are special products that become integral pieces in other kitchens and inside DeManincor kitchens.



Cooking Ranges

CR210

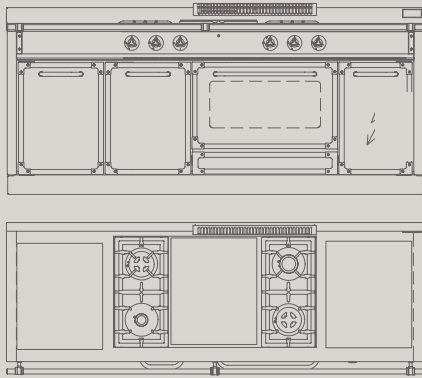

DIMENSIONS
210x70x91cm

ELECTRIC MAXI OVEN

62x41x31cm (internal dimensions) - 2.5kW
Black enameled oven with 78lt capacity and 8 cooking functions plus transversal rotisserie.
Maximum temperature 320°C.
Decorated oven door, glazed version available on demand.
Convenient compartment for tray storage under the oven.
Electric warming compartment next to the oven.

SECOND OPTIONAL ELECTRIC OVEN

(as an alternative to the warming compartment)
46x42x33 cm (internal dimensions) - 2.2kW
Black enameled oven with a capacity of 63lt and 8 cooking functions.
Maximum temperature 250°C.
Decorated oven door, available in glass upon request.
Convenient compartment for tray storage under the oven.

COOKING SURFACE

A top model thanks to its ample dimensions, it offers the possibility to satisfy even the most refined of needs in terms of typologies of cooking - anything is possible.
All design combinations are available on the following page.

CR160

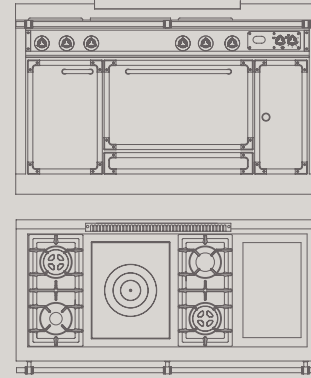

DIMENSIONS
160x70x91cm

ELECTRIC MAXI OVEN

62x41x31cm (internal dimensions) - 2.5kW
Black enameled oven with 78lt capacity and 8 cooking functions plus transversal rotisserie.
Maximum temperature 320°C.
Decorated oven door, glazed version available on demand.
Convenient compartment for tray storage under the oven.
Electric warming compartment next to the oven.

COOKING SURFACE

This model offers a wide range of combinations that can range from traditional configurations with central "Coup-de-Feu" and two double ring Gas burners with a cast iron plate, to solutions with induction burners and Teppanyaki frytop. All design combinations are available on the following page.

Islands

CI210

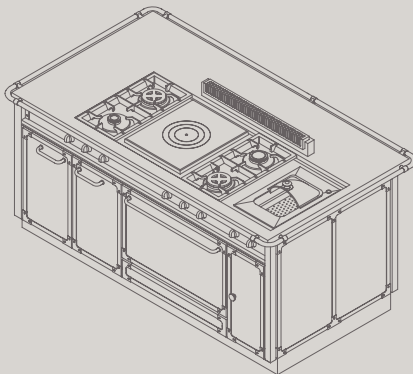

DIMENSIONS
210x100x91cm

CI160

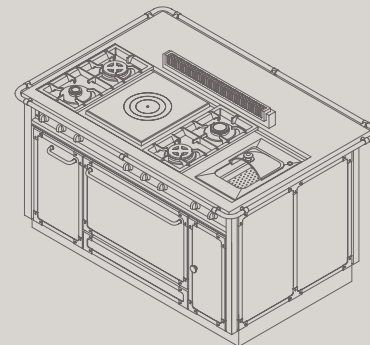

DIMENSIONS
160x100x91cm

CT210



DIMENSIONS
210x70x27cm

Top

CT160



DIMENSIONS
160x70x27cm

Cooking Ranges

CR120

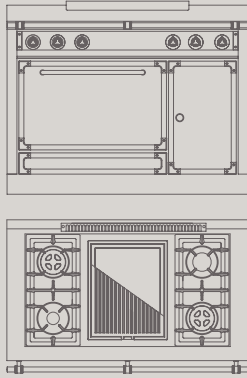

DIMENSIONS
120x70x91cm

ELECTRIC MAXI OVEN

62x41x31cm (internal dimensions) - 2.5kW
Black enameled oven with 78lt capacity and 8 cooking functions plus transversal rotisserie.
Maximum temperature 320°C.
Decorated oven door, glazed version available on demand.
Convenient compartment for tray storage under the oven.
Electric warming compartment next to the oven.

COOKING SURFACE

There are multiple potential configurations of this cooking surface even in only 120cm of space, beginning with the multifunctional double face
Gas frytop in cast iron with two double ring Gas burners.
All design combinations are available on the following page.

CR100

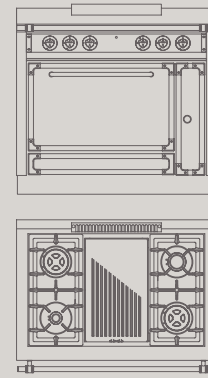

DIMENSIONS
100x70x91cm

ELECTRIC MAXI OVEN

62x41x31cm (internal dimensions) - 2.5kW
Black enameled oven with 78lt capacity and 8 cooking functions plus transversal rotisserie.
Maximum temperature 320°C.
Decorated oven door, glazed version available on demand.
Convenient compartment for tray storage under the oven.

COOKING SURFACE

Dimensions don't stand for anything even in the smallest DeManincor models, offering instead the possibility to choose between Gas with a central burner or completely induction.
All design combinations are available on the following page.

Woodburning Ranges

FCR90

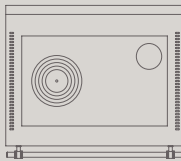

DIMENSIONS
90x70x91cm

WOODBURNING COOKING RANGE

Plate in heavy cast iron 74x75cm with traditional concentric circles.
Static wood oven 36x46x25cm
Flue overhead, behind, or lateral to either left or right.
Convenient and spacious wood box.

ACCESSORIES

Cooking plate in heavy-duty cast iron as alternative to concentric circles on the frytop.
Backguard in stainless steel for cast iron plate.

FCR60

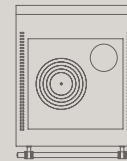

DIMENSIONS
60x70x91cm

WOODBURNING COOKING RANGE

Plate in heavy cast iron 48x45cm with traditional concentric circles.
Flue overhead, behind, or lateral to either left or right.
Convenient and spacious wood box.

ACCESSORIES

Cooking plate in heavy-duty cast iron as alternative to concentric circles on the frytop.
Backguard in stainless steel for cast iron plate.

CT120



DIMENSIONS
120x70x27cm

Top

CT100



DIMENSIONS
100x70x27cm

Technology at service to your cooking

Each of our kitchens is the result of years of technological research and experimentation that have allowed us to idealize and perfect countless solutions regarding each individual element.

From the "Coup-de-Feu" solid tops to the multifunctional ones, from the Pasta Cookers to the dish warmer positioned centrally next to the oven.

All of this and more, for an indisputably personalized product.

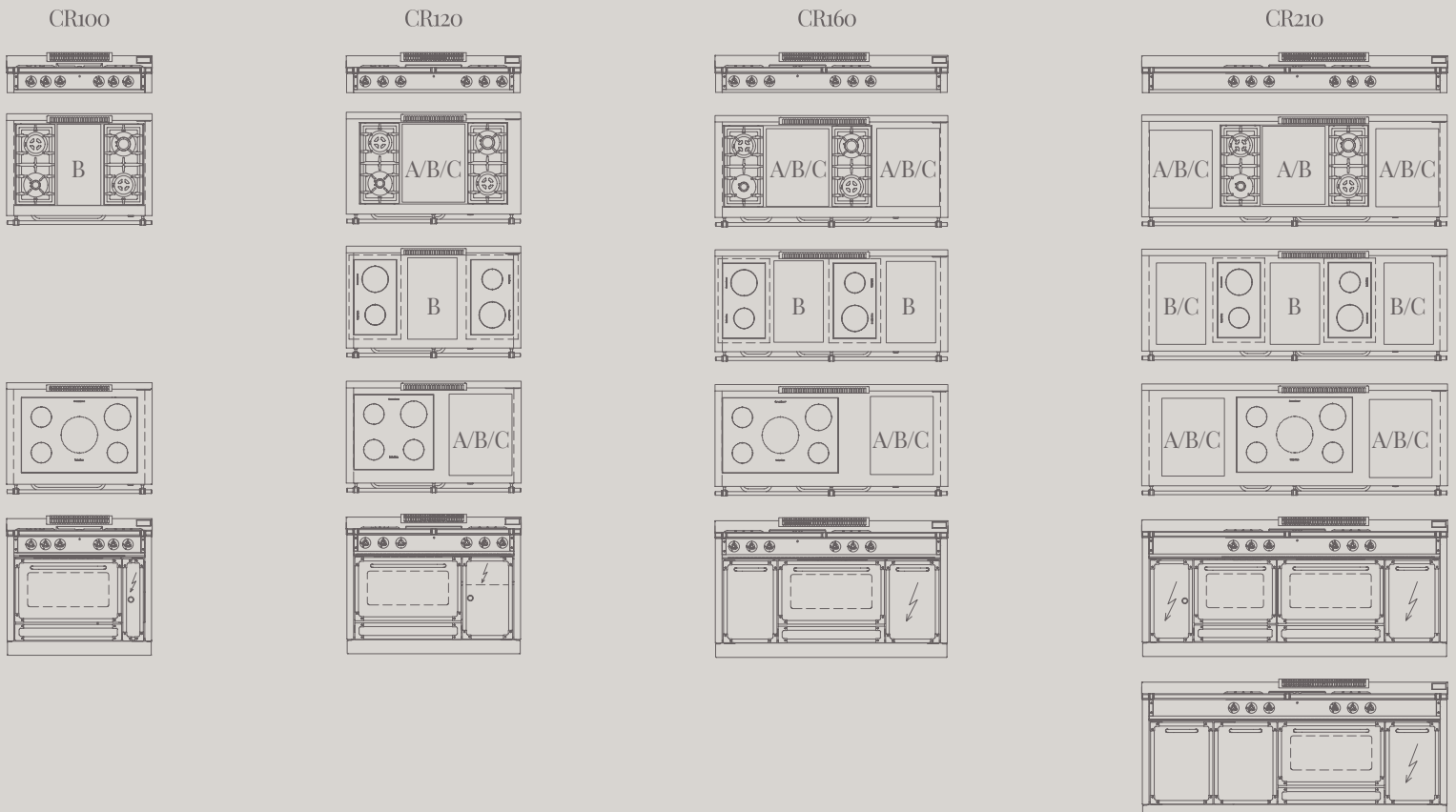

Zone B



2 watertight Gas burners from 2kW to 5kW inserted in a drainable basin for quick and easy cleaning



Powerful watertight double-ring central Gas burners of 6kW in a drainable basin for quick and easy cleaning



Multifunctional Gas frytop in polished cast iron. double face (smooth/ribbed) 30x48 cm - 4 kW



Smooth Teppanyaki Gas frytop in stainless steel. 34x48cm - 4kW



Electric frytop grill in ribbed stainless steel. 30x50cm - 4.8kW



Smooth Teppanyaki electric frytop in stainless steel. 30x50cm - 4.8kW



2 zone induction hob with booster



2 zone ceramic glass infrared hob

Zone C



Stainless steel sink melded to the top with a perimeter enclosure



Electric 13lt Pasta Cooker and 3lt Steamer



Electric fryer with 3.5lt capacity



4 zone induction hob with booster

Zone A



Gas Coup-de-Feu solid top in cast iron 39x48cm with concentric rings and adaptable Wok 4.4kW vertical flame burner



Smooth Teppanyaki Gas frytop in stainless steel. 39x48cm with 4.4kW vertical flame burner



Multifunctional Gas frytop in enamelled cast iron 39x48cm double face (smooth/ribbed) with 4.4kW vertical flame burner



5 zone induction hob with booster

Customizable color

Eleven suggested colors to start to imagine a DeManincor kitchen, but the possibilities that we offer our clients are as endless as the color spectrum itself.

Each of our panels are still hand painted in a timeless fashion, we don't limit ourselves to just a few colors or those from the RAL scale. We are dedicated to reproducing your favorite color.

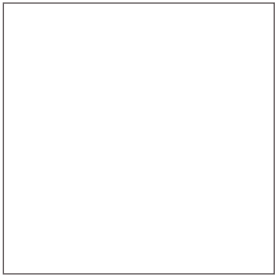

Snow
White

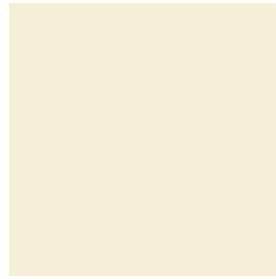

Ivory
Yellow

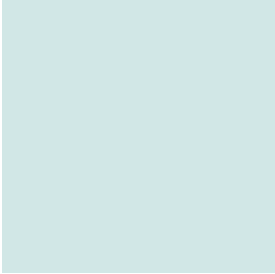

Capri
Blue



Mint
Turquoise



Peacock
Blue



Deep Ocean
Blue



India
Yellow



Monarch
Orange



Chianti
Red

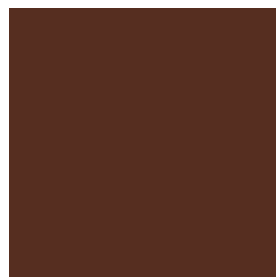

Chocolate
Brown



Absolute
Black

Material and design

From the choice of materials to the elegance of design, we realize what is necessary to achieve constant technological innovation with suggestive creativity.

From stainless steel to velvet, there are numerous materials that we can use to make your kitchen unique and special.



Satin
Stainless
Steel



Glossy
Stainless
Steel



Satin
Peltrox



Glossy
Palladium



Glossy
Copper



Glossy
Black

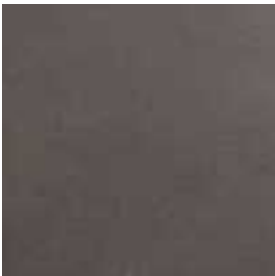

Stone
Velvet

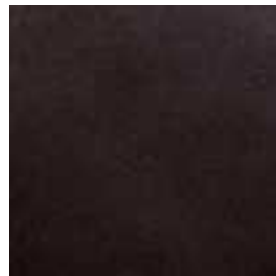

Black
Velvet



Waves
Stainless
Steel



Waves
Copper



Waves
Brass



Marble
White

Details that make the difference

They say that the difference is in the details.

We put all of our effort and passion into searching for exclusive finishes.

Incredible nuances, effects and combinations for kitchens beyond all expectations.



Satin
Stainless
Steel



Glossy
Stainless
Steel



Glossy
Brass

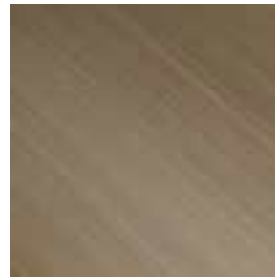

Aged
Brass



Glossy
Copper



Satin
Copper



Glossy
Palladium



Satin
Peltrox



Glossy
Black

Brand Advisory & Art Direction
THE BRANDING CREW



DeManincor SpA
Via di Spini, 15 · 38121 Trento [TN] - Italia
ph. +39 0461.99 03 22
www.demanincor.it

